



Orca H9

The Lifesaving Watercraft



HOVERSTAR FLIGHT TECHNOLOGY CO.,LTD.

Room 203/205, Bantian Group Building, 8 Shibe Road, Longgang District,
Shenzhen City, Guangdong Province, China

☎ +86-755-33138076 ✉ info@hoverstar.com 🏠 www.havospark.com

Version 1.0

User Manual

Please read the user manual carefully before using the product

The Havospark Orca H9 is a highly powerful manned water vehicle for emergency rescues. In any emergency situation, a single lifeguard can carry the H9 to the water, drive it directly towards the distressed, and take the victim back to the shore either by putting the victim on the watercraft, or fixing the victim with a buoy provided and dragging the victim back in an efficient manner. It is adaptive to swift water and also narrow, flooded areas in inner cities. The Havospark Orca H9 is a powerful, fast and easy to use hi-tech equipment for emergency water rescues.

CONTENTS

1. General Diagram
2. Cockpit Controls Diagram and Operation
3. User Interface Diagram
4. Speed and Diving Depth Limit Settings
5. Battery Level Warning
6. Faults Handling
7. Care & Maintenance
8. Charger Information
9. Operation of the Orca H9
10. Power OFF

1. GENERAL DIAGRAM

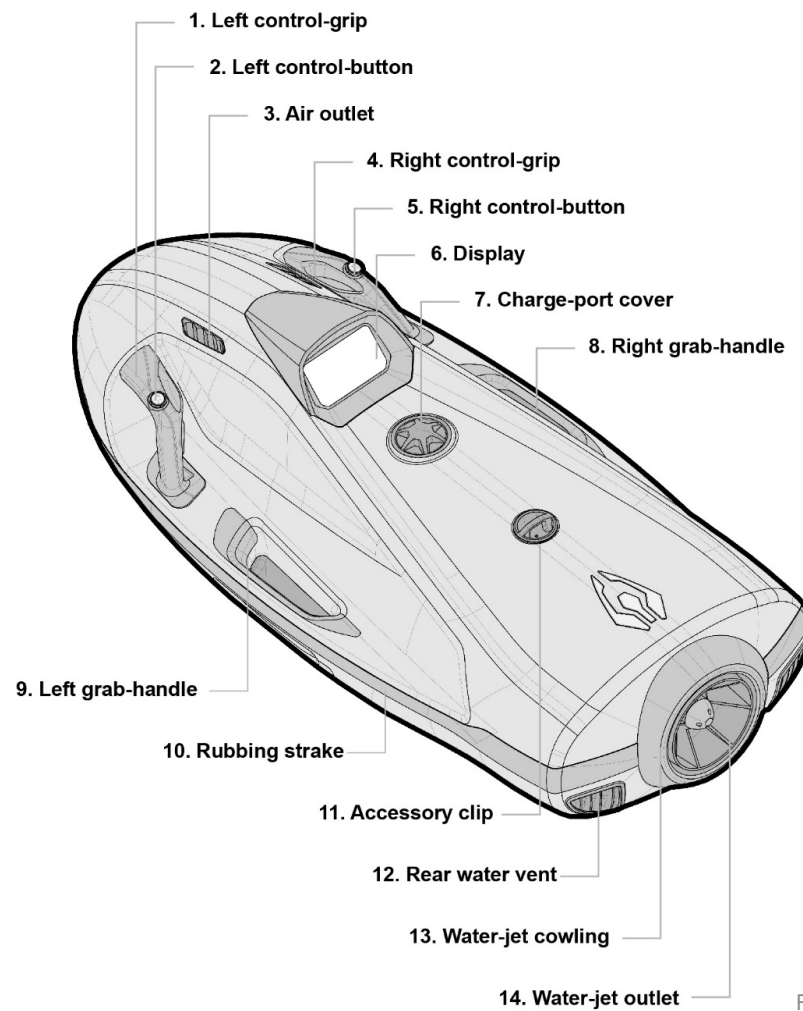

Figure 1

2. COCKPIT CONTROLS DIAGRAM AND OPERATION

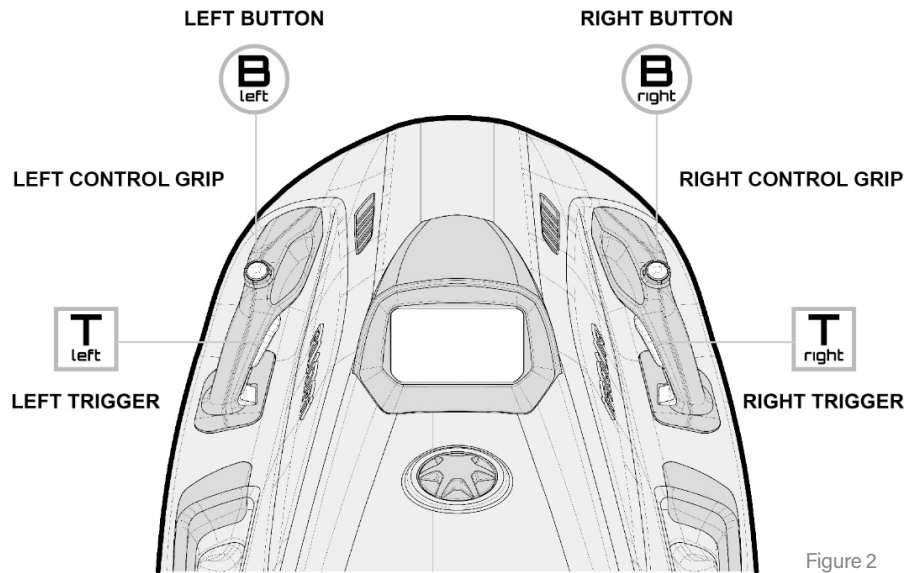

Figure 2

Left Controls

Left Button = back / gear down
Left Trigger = cancel / decrease

Right Controls

Right Button = forward / gear up
Right Trigger = confirm / increase

OPERATION INSTRUCTIONS:

- (1) Press both B-LEFT and B-RIGHT for 3 seconds to switch on or off the power!
- (2) Hold on to both handles at all time. Letting go of either grip will cause loss of power.
- (3) Both triggers need to be held to accelerate and maintain speed (release any one of it and the motor will stop working)

3. USER INTERFACE DIAGRAM

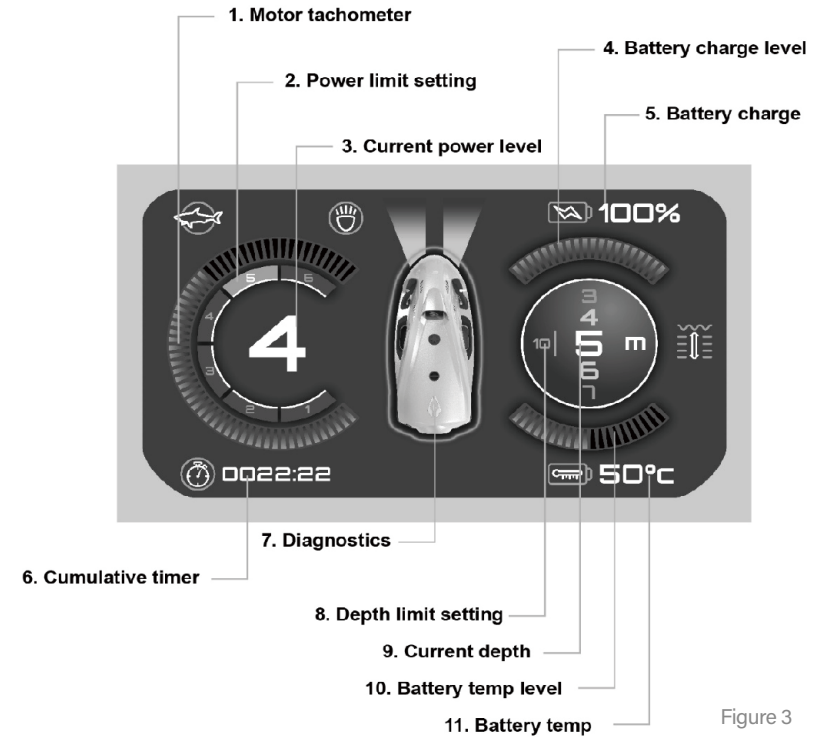

Figure 3

4. SPEED AND DIVING DEPTH LIMIT SETTINGS

4.1 SWITCH ON

When the power is off, hold both buttons (B-LEFT and B-RIGHT) for 3 seconds until the LED display screen shows a signal such as in Figure 4, which indicates the Orca H9 is starting up, as the screen says INITIALIZING (as shown in Figure 5)



Figure 4

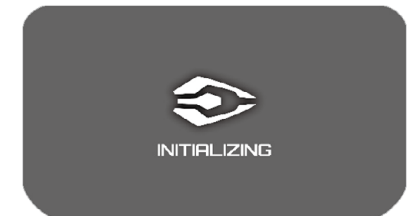

Figure 5

Press B-LEFT & B-RIGHT to scroll through the text.

Press T-RIGHT to accept and proceed to home screen.



Figure 6

The product is ready for running as it enters Figure 7.

Default depth limit = 2m

Default power limit = 3

(Each time after it is powered off, it will enter factory default setting again)

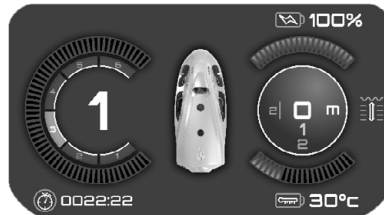

Figure 7

4.2 CHANGE THE SPEED AND DIVING DEPTH LIMIT SETTINGS

To turn off or enter settings options at any time, hold B-LEFT and B-RIGHT together for 3 seconds and enter Figure 8.

Press T-Right to enter the settings interface.



Figure 8

Power Limit Settings. Refer to Figure 9.

Press T-Left to lower power level, and T-Right to increase power level. (Power levels: 1,2,3,4,5)

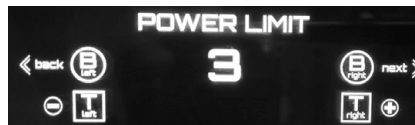

Figure 9

Choose the speed level and press B-Right to confirm and proceed to the next step (or press B-Left to return to the previous step)



Figure 10

Diving Depth Limit Settings. Refer to Figure 10.

Press T-Left to decrease and T-Right to increase the diving depth. (Diving depth options: 2m/5m/10m/20m)

Choose the desired depth level and press B-Right to confirm. To exit, press B-Left.

The settings are completed by now.

- The higher the power level limit, the faster the speed. Vice versa.

- The higher the diving depth limit, the deeper the diving depth. Vice versa.



Figure 11

5. BATTERY LEVEL WARNING

20% LEFT FOR BATTERY POWER

At this moment, the power limit is set at level 2 to maximize the use of the remaining battery power.

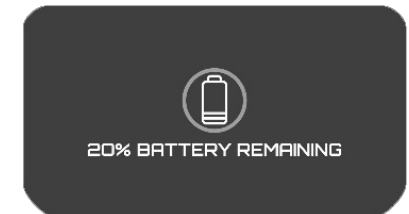

Figure 12

10% LEFT FOR BATTERY POWER

At this moment, the power limit is set at level 2 to maximize the use of the remaining battery power.



Figure 13

5% LEFT FOR BATTERY POWER

At this moment, the power limit is set at level 1. Battery power is at very low level and the equipment can be turned off automatically at any time.

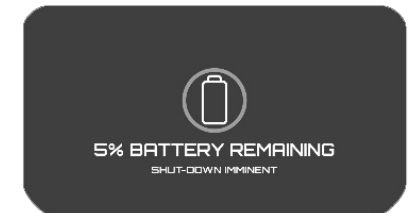

Figure 14

SHUTTING DOWN

Insufficient power to keep the equipment running. It will automatically shut down.



Figure 15

LOW BATTERY

Screen displayed when battery cannot sufficiently power-up the equipment.



Figure 16

BATTERY CHARGING

Screen displayed when unit is connected to the standard charger or fast-charger unit (see charger section)
(30% charging)



Figure 17

POWER MANAGEMENT SYSTEM

the Orca H9 is equipped with a power management system to prevent accidentally running out of battery charge during use:

- At 50% charge remaining - maximum power is limited to level 5
- At 40% charge remaining - maximum power is limited to level 4
- At 30% charge remaining - maximum power is limited to level 3
- At 20% charge remaining - maximum power is limited to level 2
- At 10% charge remaining - maximum power is limited to level 1

BATTERY INFORMATION

Nominal voltage = 48V @ 60% [50.4V fully charged] per battery pack

- Capacity = 20AH per battery pack
- Peak discharge current = 80A

6. FAULTS HANDLING

BATTERY TEMPERATURE CRITICAL

Turn unit off immediately and place in cool, shaded and well-ventilated area.

If error reoccurs frequently. Return to manufacturer for repair.



Figure 18

ELECTRONIC CONTROL UNIT ERROR

Hardware or software damage to the electronic control unit due to water leakage or overheat. Return to manufacturer for repair.

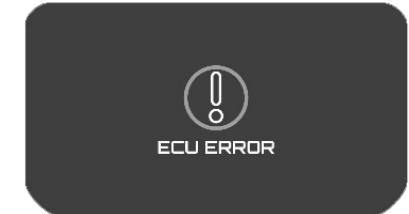

Figure 19

BLOCKAGE IN WATER JET SYSTEM

An object has entered the propulsion system preventing the propeller from turning and triggering the engine cut-off feature. Return to manufacturer for repair.



Figure 20

MOTOR TEMPERATURE CRITICAL

Usually caused by excess loading or partial jet-blockage. Turn off immediately & allow to cool.

If error reoccurs frequently, return to manufacturer for repair.

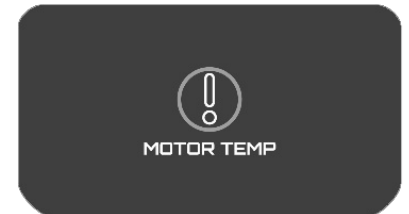

Figure 21

FATAL ERROR

Fatal system error. Unit malfunction.

Make note of code number (1-5) and return it to manufacturer for repair.

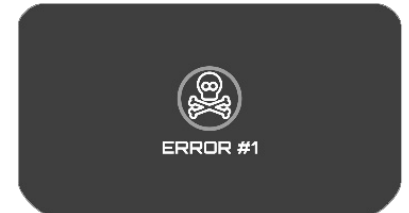

Figure 22

To perform a hard/factory reset (note: when there are errors on the display screen, or it has some problems in the operation, a hard reset can apply), press and hold B-LEFT and B-RIGHT buttons simultaneously for 15 seconds. Leave unit for approximately 2 minutes and then restart as normal.

7. CARE & MAINTENANCE

1. Only suitable for confident swimmers over 16 years of age who are fit and healthy. If you have any medical condition that may be affected by extreme sports or strenuous activity, please consult a physician before operating.
2. Always wear life-jacket or buoyancy aid in open water. Also recommend that when operated in open water, users bring a personal flotation device, whistle and beacon for attracting attention.
3. The Orca H9 is not suitable for use by persons fitted with a pacemaker due to the possible risk of interference from the electric motor and shark-guard (if fitted)
4. In case of loss of power or malfunction during diving – LET GO OF the Orca H9 AND SWIM FREE TO SURFACE. DO NOT ATTEMPT TO PULL THE UNIT TO THE SURFACE – it will float to the surface in time.
5. Do not use in strong currents, waves, bad weather or poor visibility. There must be other lifeguards or lifesaving device on standby. Recommend use of full wetsuit in cool or cold water to avoid hypothermia.
6. Holding on to the Orca H9 is physically challenging, particularly underwater where the resistance underwater is 12 times that of air. Diving with the Orca H9 is a strenuous activity and recommended that lower power levels are used when fully submerged. Power levels 4, 5 & 6 are best used at surface level. Using high power levels for sustained periods may cause injury to arms, shoulders and neck – if you feel any discomfort, drop to a lower gear or stop and take a break.
7. The Orca H9 does not guarantee 100% success in a rescue operation as an auxiliary rescue equipment. There should be a rescue personnel on standby.
8. The product has to be fully charged before each use.
9. Never dip a finger or put objects into the covered propellers section in case of injury or damage to the propellers or its components.
10. Upon receiving a low power warning (refer to section 5, BATTERY LEVEL WARNING), please stop using it immediately and charge it as soon as possible.
11. When approaching the victim with the Orca H9, please slow down to avoid bumping into the victim and cause unnecessary injuries.
12. The Orca H9 uses high discharge rate lithium-ion battery, which has to be recharged every three months if left unused.
13. For any personal injury or property loss due to improper use, the user should be held responsible.
14. Maintenance should only be carried out by professional technicians. Please do not disassemble, dismantle the product or disconnect batteries by yourself or any unauthorized person.
15. When the charging is completed, make sure the waterproof charging port has been screwed on tightly.
16. It is strongly recommended that the user get familiarized with the operation of the Orca H9 before using it in rescue operations.
17. Do not apply throttle if unit is tethered or operating against a solid object.
18. Do not block the water inlet or outlet ports of the Orca H9.
19. Do not use within 1m of seabed, shallow water under 1m of depth or in sediment. Use in shallow water or sediment will cause the water-jet system to ingest sand and debris which will cause damage to propeller, seals and bearings.
20. Never drop or throw the Orca H9 into water from a height greater than 50cm or jump from elevated location holding the Orca H9. The shock and stresses may cause internal damage or cracks to the composite and plastic components.
21. In case of waterjet ingesting seaweed, rope or any material that blocks the internal propeller, the Orca H9 will automatically stop power to the drive system. If the offending object is visible and simple to remove, return unit to a dry surface, turn the unit off using the main menu function, place upside down on a smooth clean surface and extract manually.
22. Do not operate the Orca H9 out of water – the battery system and shaft seals will quickly overheat in free air.
23. Do not disassemble or modify the Orca H9 in any way. Adding supplementary equipment such as bracketry that require modification of the bodywork may compromise the strength of structural components causing stress fractures and will invalidate the warranty.
24. Ensure your Orca H9 is in good physical and electrical condition before usage. Check each time for cracks in hull or bodywork, misalignment of components or faults on the display – see diagnostics section for error codes.
25. Do not leave the Orca H9 in direct sunlight for prolonged periods. The surface temperature of the Orca H9 bodywork may cause burns in hot environments. Sustained heat may also shorten the life of your batteries or cause them to malfunction. Please store in a shaded area and use the reflective cover when shade is not available.
26. Always rinse through with fresh water after every use. Salt water is extremely corrosive, therefore accumulated salt deposits on internal components or bodywork would reduce the life of the Orca H9 unit.
27. Do not use abrasives, alcohol-based or acid-based cleaning products to clean the Orca H9. Use fresh water with a little detergent or car wash solution with a soft damp cloth.
28. Use the original the Orca H9 packaging supplied with the unit to store it when not in use. Ensure the drainage plug has been removed from the base of the packing box.
29. Ensure the Orca H9 is thoroughly drained and allow to dry thoroughly before transporting or putting into storage.

8. CHARGER INFORMATION

Make sure the provided charger and adapter is used for the charging. Using a charger not provided with the product for performing the charging process could result in overheat or possible burning. Please always charge the Orca H9 in a cool, dry and well ventilated environment.

DIAGRAM OF CHARGER

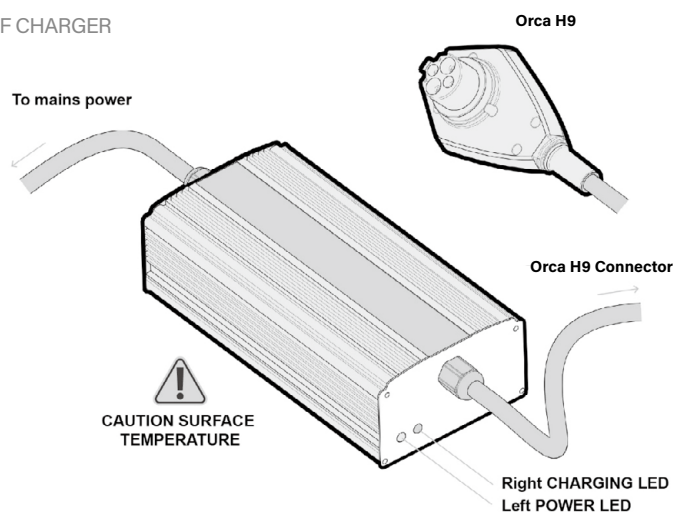

Standard charger light indicators

POWER ON	● ○	Single RED LED on left illuminated
CHARGING	● ●	Both RED LEDs illuminated
FULLY CHARGED	● ●	RED LED on left & GREEN LED on right illuminated

Figure 23

CHARGING PROCEDURE

1. Move the Orca H9 and charger to sheltered, dry, clean & well-ventilated area.
2. Ensure the Orca H9 unit and charger are both switched off.
3. Remove the protective charger cap and place it to somewhere dry and clean.
4. Ensure there is no moisture, sand, grease or debris in any part of the female or male connector. Wipe clean with a dry cloth if necessary.
5. Connect the male connector on the lead to the female connector on the the Orca H9 unit.
6. Switch on the charger.
7. When batteries are fully charged (standard charger full charge = approximately 6 hours & fast charger full charge = 2 hours), switch off the charger.
8. Disconnect charger lead from the Orca H9 unit.
9. Ensure there is no sand, moisture, grease or debris on the charger cap or charge port and replace cap.
10. Tighten the cap to finger tight. Excessive tightening may damage the thread or O-ring seal. Insufficient compression will allow water to penetrate the connector and cause a short circuit.

WARNINGS FOR CHARGING

1. We recommend periodically charging the Orca H9 when in long-term storage to help prolong the battery life. For ambient storage temperatures under 25 °C (77 ° F) - charge once every 3 months, for ambient storage temperature over 25 °C (77 ° F) - charge once every 2 months.
2. For air-freight shipping, please discharge batteries to 30%.
3. Ensure the charger lead is connected to the Orca H9 charge port before turning the charger on. Failure to do so may cause a surge or sparks between male and female connector.
4. Regularly check the charge cover cap and seals. O-rings degrade over time and may require replacing.
5. Do not obstruct the fan on the charger units, as it will cause the charger to overheat and automatically cut-off.
6. Keep the charger away from flammable substances. Small sparks may be caused when connecting the lead to the charge port.
7. Batteries are designed to go through approximately 1200 charge/discharge cycles, and the charge capacity will gradually reduce over time. We recommend replacing the batteries after 36 months or 1000 charge/recharge cycles.
8. Expired lithium Ion batteries need to be professionally disposed or recycled. Do not burn / incinerate or throw in regular domestic trash. Please consult your local council / government on how to properly dispose in your locality.
9. Ensure the charger is always used with an earth connection – without a good ground connection the charger can build in casing and there is a risk of electric shock, especially in humid or salt-water environments.

CHARGER SPECIFICATIONS

Standard charger (supplied with the Orca H9)		Fast charger (additional cost accessory)	
Charging time	100% = 6 to 7 hours	Charging time	100% = 2 hours
Charging voltage	51V DC	Charging voltage	51V DC
Charging current	6A	Charging current	20A
Input voltage range	110V to 240V AC	Input voltage range	110V to 240V AC
Power consumption by fast charger	1020 Watts	Power consumption by fast charger	1020 Watts
Power consumption by normal charger = 306 Watts		Fast charger is to be used sparingly. Frequent use of it will shorten the battery life.	

Standard charger is recommended for regular use to prolong the life of the batteries.

Difference in Charging (standard charge vs. Fast charge)

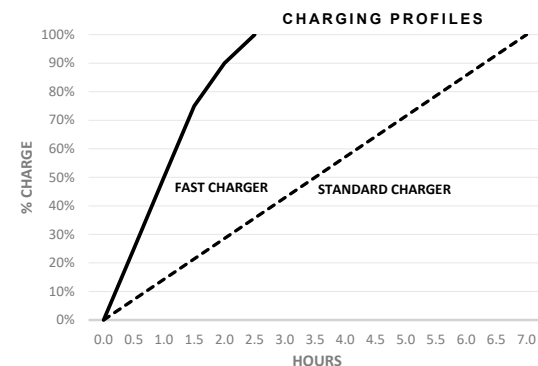

Figure 24

9. OPERATION OF THE ORCA H9

SWITCH ON

When the power is off, hold both buttons (B-LEFT and B-RIGHT) for 3 seconds until the LED display screen shows a signal such as in Figure 25, which indicates the Orca H9 is starting up, as the screen says INITIALIZING (as shown in Figure 26)

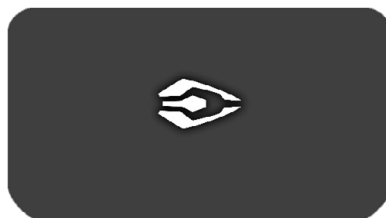

Figure 25

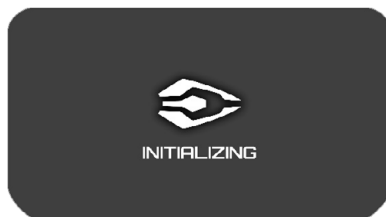

Figure 26

Press B-LEFT & B-RIGHT to scroll through the text.

Press T-RIGHT to accept and progress to home screen.



Figure 27

The product is ready for running as it enters Figure 27.

Default depth limit = 2m

Default power limit = 3

(Each time after it is powered off, it will enter factory default setting again)



Figure 28

Operation of the Orca H9

- Both triggers need to be pressed for the Orca H9 to accelerate and maintain speed (B-Right for accelerating and B-Left for gear down)
- Hold on to both handles at all time. Letting go of either grip will cause loss of power.

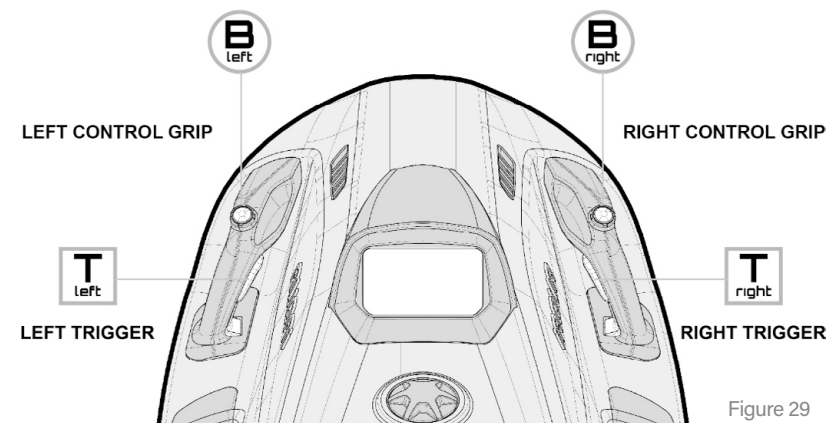

Figure 29

Left Controls

Left Button = back / gear down
Left Trigger = cancel / decrease

Right Controls

Right Button = forward / gear up
Right Trigger = confirm / increase

Notes:

- The direction and orientation of the Orca H9 is controlled by your body movement and requires thrust from the waterjet to manoeuvre. The faster it is running, the harder it will be for manoeuvring the Orca H9 with your body.
- The only contact points between the operator and the Orca H9 are the control handles.
- The brake of the Orca H9 uses two hand fault protection system, which means if the user release any trigger, the motor will stop working immediately.
- Adjust your position so the Orca H9 will run true and horizontal on the water's surface.
- Diving with the Orca H9 requires little effort by pushing the nose down, it will run horizontal at all depths without much effort. To resurface needs a minor change in direction, pointing the nose upwards and applying power.

10. POWER OFF

When the power is on, press and hold both the B-Left and B-Right button for 3 seconds to enter Figure 30.

And then press T-Left to switch off the power.



Figure 30

***Note:** for power and diving depth limit setting, please refer to section 4 (4.SPEED AND DIVING DEPTH LIMIT SETTINGS)